

**IMPORTANT: CUSTOMER & INSTALLER TO READ THIS MANUAL PRIOR TO INSTALLATION & USE!**

**RIDG-U-RAK**

**INSTALLATION GUIDE**  
**FOR**

**ISLAND DRIVE-IN**  
**STORAGE SYSTEMS**

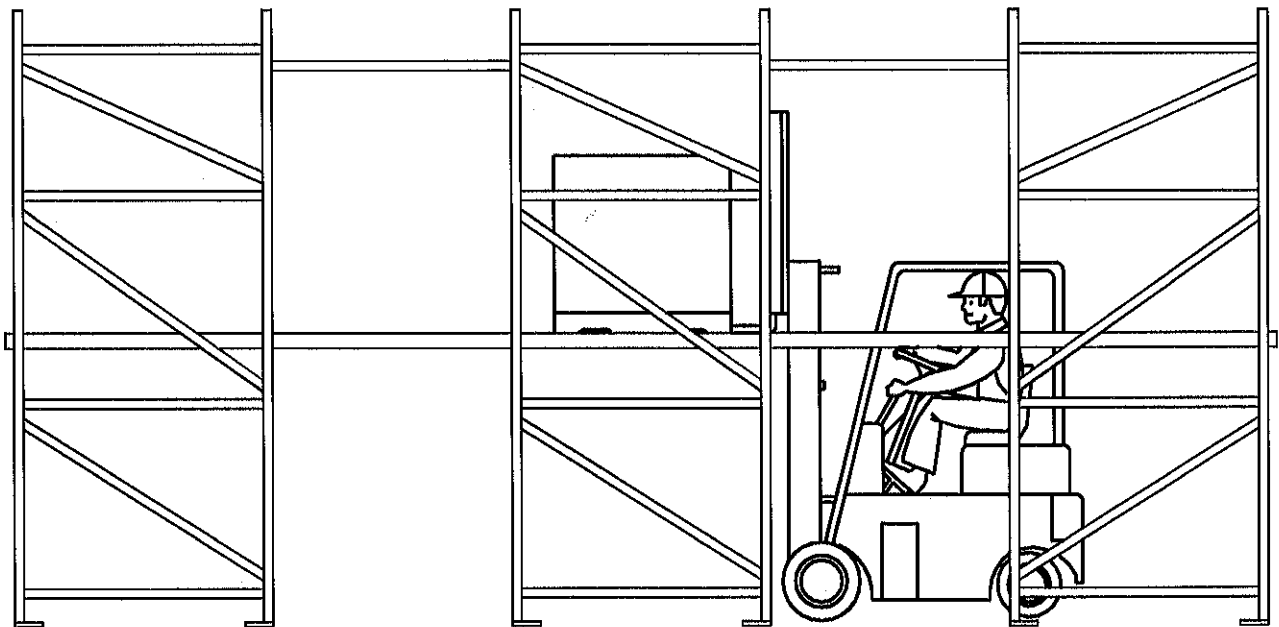

# ISLAND DRIVE-IN INSTALLATION GUIDE

## **CONTENTS**

- I. INTRODUCTION
- II. IMPORTANT GUIDELINES FOR INSTALLATION
- III. SHIPMENT CHECK & UNLOADING INSTRUCTIONS
- IV. GENERAL DESCRIPTION OF SYSTEM
- V. FAMILIARIZING YOURSELF WITH THE RACK SYSTEM
- VI. INSTALLATION PROCEDURE
- VII. COMPLETION CHECK
- VIII. BOLTING AND LOCKING DEVICE DETAILS
- IX. OPTIONAL COMPONENTS
- X. RACK PROFILES
- XI. SPECIAL INSTRUCTIONS
- XII. SUPPLEMENTAL DRAWINGS & DOCUMENTS

## I. INTRODUCTION

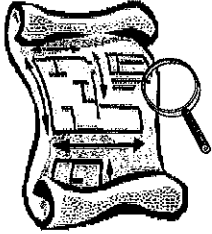

All instructions, including building construction drawings, Ridg-U-Rak drawings and this installation guide should be reviewed thoroughly by the customer and the installer before installation begins. By doing so you will provide yourself with a basic guide for erecting an ISLAND DRIVE-IN rack system. Many factors, which vary from each installation, can determine the best procedure for erecting the system. Therefore your crew may require alternate methods and steps. The success of the installation will ultimately depend on the experience and skill of the installation crew.

## II. IMPORTANT GUIDELINES FOR INSTALLATION

1. Damaged racks must be addressed by the customer immediately. Failure to do so could result in rack component failures.
2. Do not store rack material outdoors. Extensive damage may occur. The standard painted finish is not intended for outdoor storage.
3. Compatibility and correctness of materials supplied by other manufacturers for use with the rack system is not the responsibility of Ridg-U-Rak.
4. The rack must be installed using all components and hardware specified. Elimination of components or hardware should never be attempted.
5. Use of the rack for supporting loads beyond that for which it is specifically designed for, i.e. (sprinkler pipes, refrigeration equipment, etc.) should not be attempted.
6. Installation should be performed under the guidance and supervision of a person that is a qualified and experienced rack installer.
7. It is important that all personnel wear hard hats while installing bolted connections.
8. Proper floor design to accept the loading conditions imposed upon it by the rack structure shall not be the responsibility of Ridg-U-Rak.
9. Use of the rack as scaffolding, or climbing on the rack, is not recommended. Persons using the rack for these purposes shall do so at their own risk.
10. Never install beams from both ends of the row at the same time. Always start at one end only, or from the center of a row and work both ways.
11. Normally a rawhide faced hammer or urethane hammer may be used for installing beams.

**\* PLEASE NOTE : ALTHOUGH IT IS RECOMMENDED FOR ALL ISLAND DRIVE-IN RACK SYSTEMS.**

**RACKS OVER 5 PALLETS DEEP MUST BE TIED TO BUILDING COLUMNS OR OTHER**

**BUILDING MEMBERS FOR LATERAL STABILITY.**

### III. SHIPMENT CHECK AND UNLOADING INSTRUCTIONS

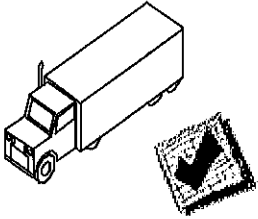

It is important that you thoroughly check the shipment against the bill-of-lading supplied with each truckload as soon as it arrives. Separate the shipment into groups of identical items. Check each item to assure that the physical quantities received agree with the bill-of-lading. While doing this you should familiarize yourself with the components and their nomenclature which will be used throughout this guide. Our responsibility for this shipment will cease when you sign for it after it arrives at your facility! If any goods called for on the bill-of-lading are short or damaged, do not accept this shipment until the freight agent makes a damaged notation on your freight bill. If any concealed loss or damage is discovered, notify your freight agent at once and ask him to make an inspection. This is absolutely necessary. Unless you do this, the transportation companies will not entertain any claim for loss or damage. If the agent will not make an inspection, then you should make an affidavit that you notified him (on a certain date) and he failed to do so. This, with other papers, will support your claim.

### IV. GENERAL DESCRIPTION OF SYSTEM

Island Drive-in rack systems are accessed from two sides by narrow aisles that run 90 degrees to the working aisles. These narrow aisles actually proceed into the Island Drive-in rack up to the centrally located basic beams. "Island" refers to the island like location of basic beams near the middle of an Island Drive-in rack system bay. Pallets are stored in these aisles, both on the floor and on the parallel rails above the floor. Island Drive-in racks provide very high storage density but very low selectivity. Island Drive-in rack systems are best suited for first-in last-out storage requirements. Although it is recommended for All Island Drive-in rack systems, racks over 5 pallets deep must be tied to building columns or other building members for lateral stability.

### V. FAMILIARIZE YOURSELF WITH THE RACK SYSTEM



Due to the numerous types of Island Drive-in rack systems, "Supplemental Drawing(s)" and a "Bill of Material" are generally required. They will show the rack front and side profile along with the locations and dimensions of frames, spacers, etc. for the system. They will also indicate special features and optional components. Reading this guide and studying the drawing(s) and documents associated with this installation package is an important starting point in your installation. Any question regarding the layout, installation procedure, components, or documents after thoroughly reading this installation guide and supplemental drawing package should be brought to the attention of Ridg-U-Rak, Inc.

## VI. INSTALLATION PROCEDURE

### Step 1. CLEAR AREA

Installation area must be free and clear.

### Step 2. CHALK LINES

The key to a good installation begins with an accurate floor layout. Using a tape measure and a chalk line, establish a grid pattern showing the front of each bank in the system and all frame centerlines. Placement of the rack will be established either by the customer or from drawings supplied by the customer or distributor.

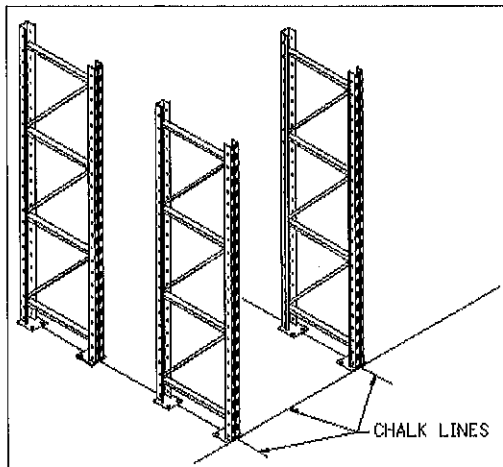

(NOTE: It should be certain before using drawings that the customer has approved them for construction).

### Step 3. SHIMMING

A laser or any surveying equipment may be used to establish any deviations in the floor. Find the high point of the floor in the area where the racking will be installed. Mark the floor or a chart with the information so each frame can be shimmed to establish a level system. The system must be level within 1/2" per 10' of height.

### Step 4. COMPONENT and HARDWARE IDENTIFICATION

The parameters for the Island Drive-in rack system beams, frames, rails, rail supports and any other component may be found within the item description of the "Bill of Material" (see below). You may also reference the "Rack Profiles", "Special Instructions", "Supplemental Drawing(s)" or contact Ridg-U-Rak to identify components and their locations in the system. Check before installing each item that it is correct for that location. All hardware is A-325 high strength bolts and nuts. Do not, under any circumstances, use any hardware other than that which is specified without approval from Ridg-U-Rak, Inc. Refer to the "Supplemental Drawings" and "Bolting & Locking Device Details" of this guide to determine the correct hardware for all connections.

**EXAMPLE:** Bill of material (See the supplemental drawing package and / or bill of material for the information that is specific to your Island drive-in rack system).

ITM #	MAPICS #	ITEM DESCRIPTION	ORDER QUANTITY	UNIT WEIGHT
1	506499	UP-R-43-D-17.00-12 01-00-14-0	27.000	175.917
		ENG. DRAWING # 506499 REVISION # 01		
		UPRIGHT FRAME POST GREEN - FOREST		
2	505683	US-H-43-D-17.00-48 01-00-60-0	54.000	253.743
		ENG. DRAWING # 505683 REVISION # 02		
		UPRIGHT SLANT GREEN - FOREST		

Upright slant-bak frame.  
4" X 3" posts, 17.00 ft. tall  
X 48 in. wide.

### Step 5. RACK PROFILE

Island Drive-in rack systems should be started with the erection of a single bay. Refer to the proper "Rack Profile" (provided herein), the "Supplemental Drawings" & the "Bill of material" prepared for this particular system. The "Special Instructions" herein may also contain pertinent information. Identify and gather the correct components for a single bay at this time. Be sure to check for special or optional components before initiating the installation process. See "Optional components" herein.

**EXAMPLE:** RACK PROFILE (See the supplemental drawing package for the rack profile that is specific to your Island drive-in rack system).

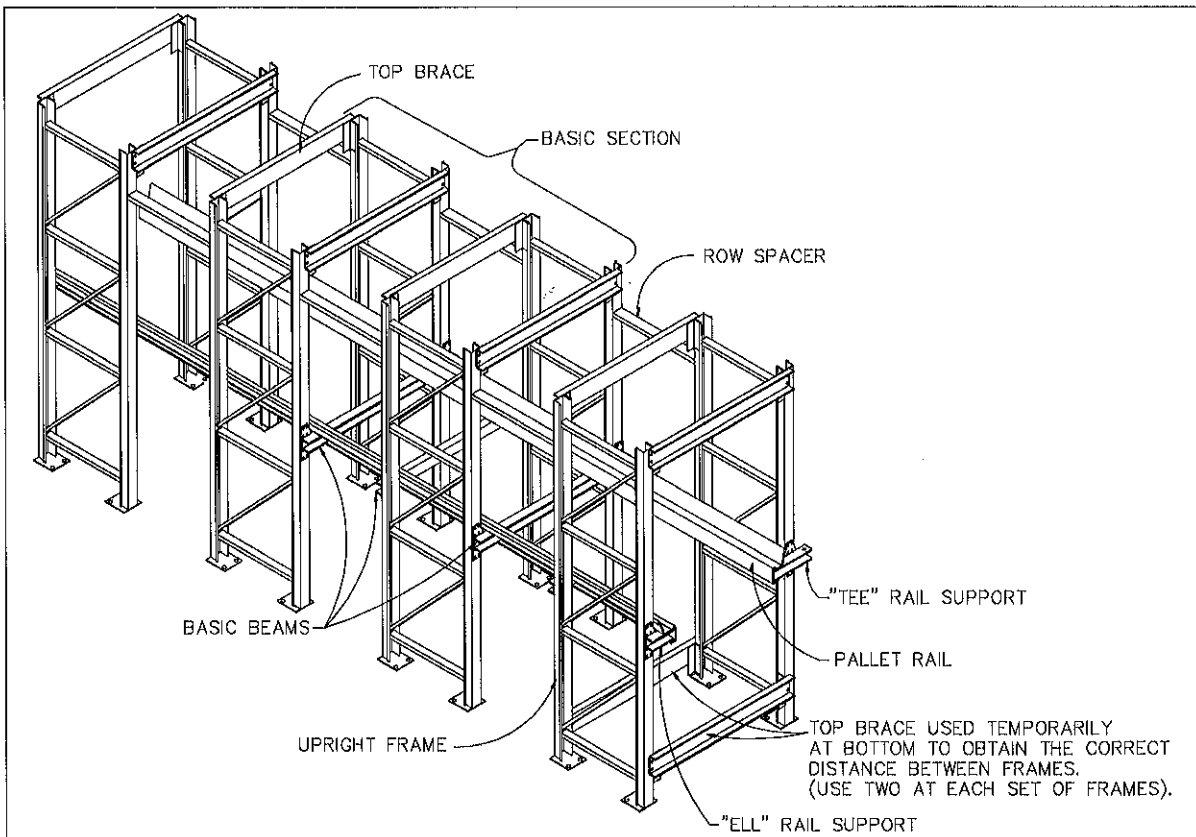

**Step 6. SUB-ASSEMBLY OF “TEE” AND “ELL” PALLET RAIL SUPPORTS TO UPRIGHTS**

The “tee” and “ell” pallet rail supports can be assembled to the Island Drive-in rack upright frames and frame-posts where necessary before raising them into position. Elevate the frames off the floor in a safe manner.

**Step 7. ERECTING A STARTER BAY (raising the first upright frame)**

It is necessary when assembling an Island Drive-in rack to begin with the “basic section” or the section of the rack containing the basic beams. The basic section, once erected, will give the rack lateral stability and establish the center to center of bays. Start at the first frame location. Place the base of the first frame on line and raise it to a vertical position. Recheck to be sure that it’s on the proper line. Raising the upright is accomplished manually with relative ease by having one or two people place their feet on the base pads and two or three people raise the frame to a vertical position. This procedure will work with up to 23’ or 24’ upright frames. If the upright is too heavy, use a forklift truck to raise it. Be sure that the frame depth, height, style etc., and also the slope of the diagonal braces are correct. Frames are generally installed with the column at the high end of the diagonal brace as the front of the frame.

**Step 8. RAISING THE SECOND UPRIGHT FRAME**

With one or two people supporting the frame, repeat the procedure as outlined in #7 above, raising the next upright frame to a vertical position. Place frames with brace patterns identical to each other. With someone holding the frames in their general locations, place the basic beams in their correct locations and hand-tighten all bolts. \*Note: Position beams to assure a safe and steady starting structure before releasing the steadying hold on the frames. Install a temporary top brace at a lower location of 12” from the floor at all uprights to steady the structure. This will also serve as an excellent means of obtaining the correct distance between frames. (Reference the illustration at the bottom of page 4)

**IMPORTANT:** Hand tighten all bolted frame / structure connections at this time. Do not torque until the bay is complete.

**Step 9. INSTALLING REMAINING BEAMS AND FRAMES OF THE STARTER BAY**

As stated in numeral “V” there are many rack profiles. This is primarily due to the depth of the system and the number of levels. In order to erect a Starter Bay it is necessary to utilize the “Rack Profiles” (provided herein), “Supplemental Drawing(s)” and the “Bill of Material” for the correct profile and components. Stand the remaining frames and/or frame-posts for the first bay and secure them in position by installing the top braces if they require them. Install temporary top braces near the bottom of ALL uprights as an aid in keeping the frames spaced correctly.

\*NOTE: In the case where no top braces are required on the frames it will be necessary to bolt the pallet rails to the basic beams prior to standing the forward frames. This will enable the forward frames and/or frame-posts to be bolted to the pallet rails as they are stood.

#### Step 10. INSTALLING SPACERS

Spacers can be installed once you have frames standing with the correct beams in place. Generally spacers should be installed with the first one as close to the top as possible and additional spacers positioned down in 6-ft. increments. The number of spacers is determined by the frame height (see the “Supplemental Drawings”) and the “Spacer/Frame Height Chart within the “Rack Profiles” (provided herein).

#### Step 11. INSTALLING THE PALLET RAILS

Pallet rails should be installed on both sides of the interior and also on the outside on one side of the first bay. The rail installed on the outside becomes an interior rail when the second bay is erected. Pallet rails extend 3” out from the end frames in most cases. In some cases the pallet rails may be made up of several sections which are either spliced together or require the installation of a special “tee” or “ell” splice at this area. See the Bolting & Locking Device Details”, “Supplemental Drawings” and the “Bill of material” to determine the correct hardware and splicing for all connections. Install all components necessary to complete the starter bay.

#### Step 12. INSTALLING OPTIONAL COMPONENTS

Be sure to double check for Special Features and for optional components. See “Optional components” herein, the “Bill of Material” and the “Supplemental Drawings” for further information.

#### Step 13. SHIMMING THE STARTER BAY

Shim the frames, if needed, with Ridg-U-Rak metal shims (or equivalent) at this time. The rack manufacturers institute (R.M.I.) requires that frames be plumb within 1” per 10’ of height. Ridg-U-Rak recommends that all rack frames be level within 1/2” per 10’ of height.

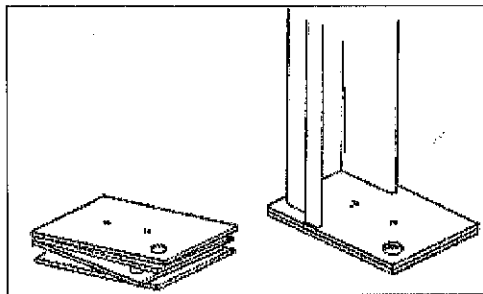

#### Step 14. TIGHTENING AND TORQUEING ALL BOLTED CONNECTIONS

Bolted connections in the rack system should now be tightened and torqued to the proper specifications. (Refer to the “Bolting & Locking Device Details” section herein).

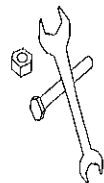



**Step 15. LAGGING THE FIRST BAY**

The first bay should be near complete, shimmed to within 1/2" per 10' of height and correctly positioned on the chalk lines. Refer to the floor chart or markings on the floor that were made in Step 3 for shimming. Add Ridg-U-Rak metal shims (or equivalent) as required by your chart or markings. (Ridg-U-Rak shim thicknesses available: 1/16" 1/8", 3/16", 5/64" and 7/64"). Lag only the end frames and/or frame-posts at this time. The remainder of the lagging will be done as the system is installed. Lagging the end frames will ensure that the rack system stays in position. Lag bolts must be of the type specified in the "Supplemental Drawings", "Special Instructions" herein or the "Bill of Material".

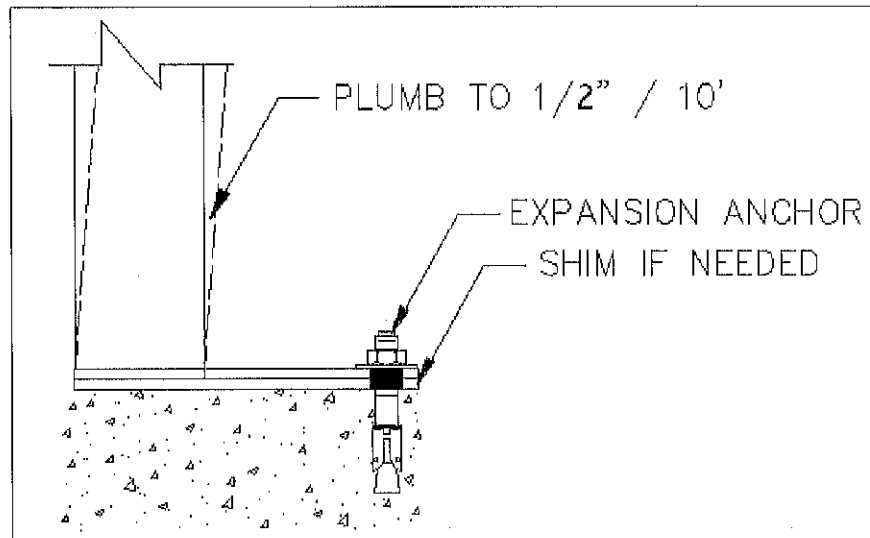

**Step 16. COMPLETING A BANK OF DRIVE-IN RACK**

After successful completion of the first bay, install the remaining bays in a similar manner:

- A. Assemble "tee's" and "ell's" to frames and frame-posts where necessary.
- B. Erect the next basic section.
- C. Erect remaining components of the bay.
- D. Install optional components if necessary.
- E. Tighten spacers and any other bolted frame / structure connections.
- F. Anchor the next set of frames (one side of bay) after ensuring that they are properly shimmed under each post and correctly squared to the previous frames / posts.
- G. The temporary top beam used at the floor level may be removed after the frames at each end of the brace have been lagged.

This procedure must be followed for each bay until the entire bank is complete.

(Reference steps 6-16)

Step 17. TECHNICAL ASSISTANCE

If after reading all documents, guides and drawings, you are experiencing difficulty during the identification, erection, or any other aspect of the installation of the ISLAND DRIVE-IN system, please call Ridge-U-Rack at (814)-725-8751. If we receive a call from an installer on site with a cellular phone, we can sort out questions or difficulties, usually without delay.

**VII. COMPLETION CHECK**

Check the following items before releasing the rack system for customer use!

HAVE YOU:

- Installed all required component parts including optional components ?
- Installed, tightened and torqued all bolts or connections to the required specifications as shown in the "Bolting & Locking Device Details" herein ?
- Plumbed and leveled all frames and posts within the applicable tolerances ?
- Anchored all frames and posts with the correct anchors ?
- Cleaned up the work site to provide a safe working environment ?

# VIII. BOLTING & LOCKING DEVICE DETAILS

NOTE: All bolts and nuts are "A-325" grade and plated unless specified otherwise.

## CONNECTION DESCRIPTION & TORQUE REQUIREMENTS

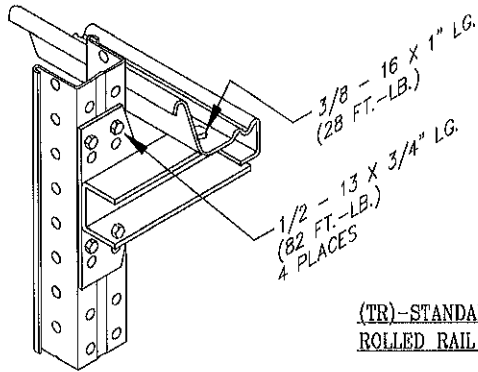

(LR)-STANDARD ELL FOR ROLLED RAIL

(TR)-STANDARD TEE FOR ROLLED RAIL (NOT SHOWN)

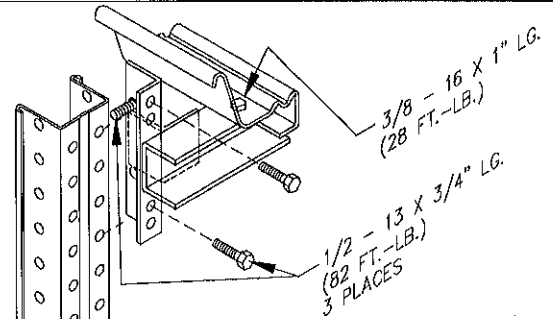

ALTERNATE ELL FOR ROLLED RAIL

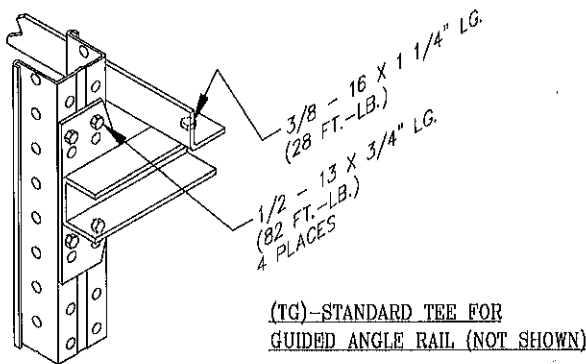

(LG)-STANDARD ELL FOR GUIDED ANGLE RAIL

(TG)-STANDARD TEE FOR GUIDED ANGLE RAIL (NOT SHOWN)

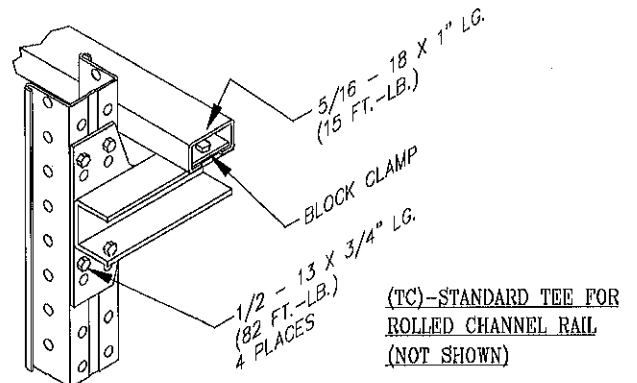

(LC)-STANDARD ELL FOR ROLLED CHANNEL RAIL

(TC)-STANDARD TEE FOR ROLLED CHANNEL RAIL (NOT SHOWN)

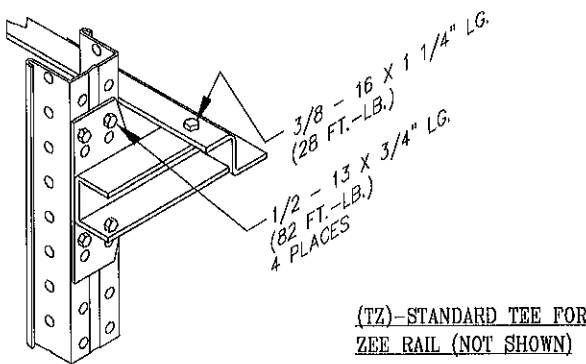

(LZ)-STANDARD ELL FOR ZEE RAIL

(TZ)-STANDARD TEE FOR ZEE RAIL (NOT SHOWN)

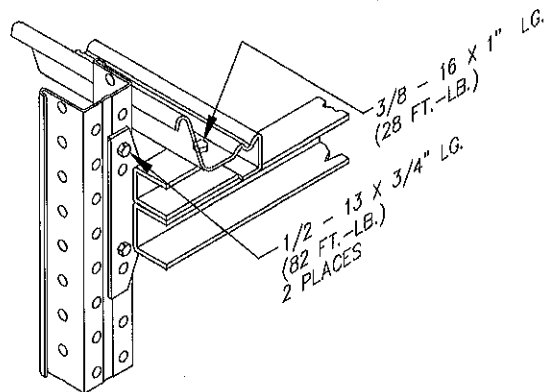

(BR)-STANDARD BASIC BEAM FOR ROLLED RAIL

# VIII. BOLTING & LOCKING DEVICE DETAILS (continued)

NOTE: All bolts and nuts are "A-325" grade and plated unless specified otherwise.

## CONNECTION DESCRIPTION & TORQUE REQUIREMENTS

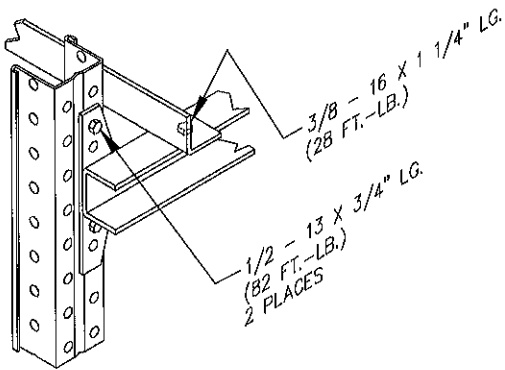

(BG)-STANDARD BASIC BEAM FOR GUIDED ANGLE RAIL

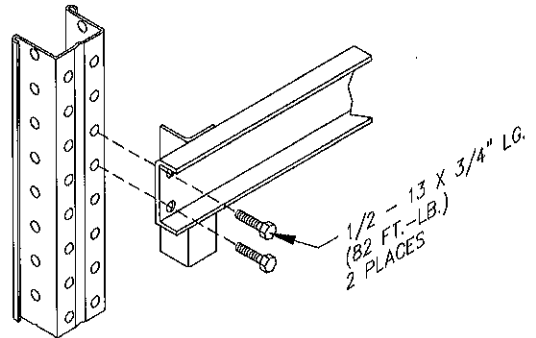

STANDARD TOP BRACE

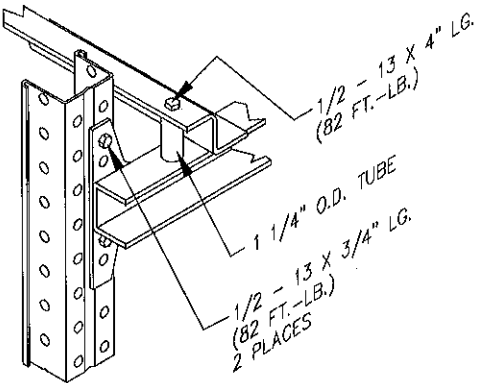

(BZ)-STANDARD BASIC BEAM FOR RZ-32 AND RZ-33 ZEE RAIL

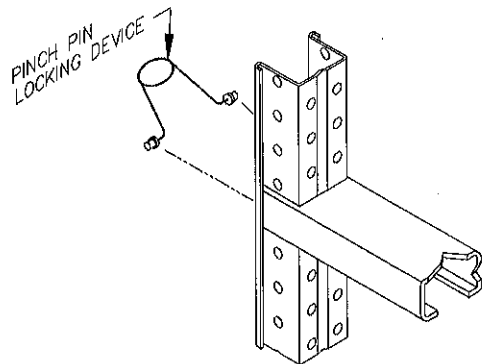

(RS)-STANDARD ROW SPACER

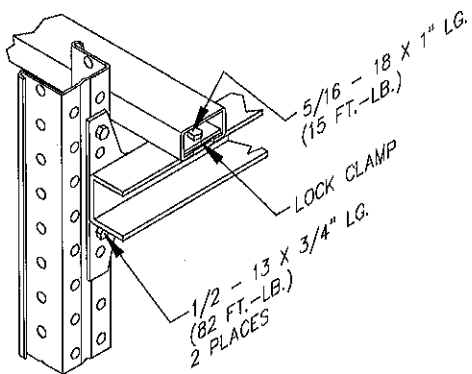

(BC)-STANDARD BASIC BEAM FOR ROLLED CHANNEL RAIL

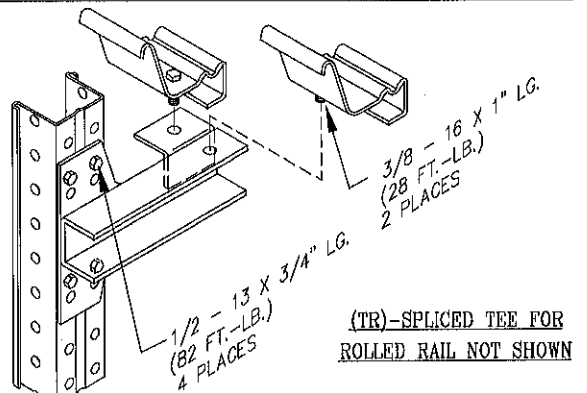

(LR)-SPICED ELL FOR ROLLED RAIL

(TR)-SPICED TEE FOR ROLLED RAIL NOT SHOWN

# VIII. BOLTING & LOCKING DEVICE DETAILS (continued)

**NOTE:** All bolts and nuts are "A-325" grade and plated unless specified otherwise.

## CONNECTION DESCRIPTION & TORQUE REQUIREMENTS

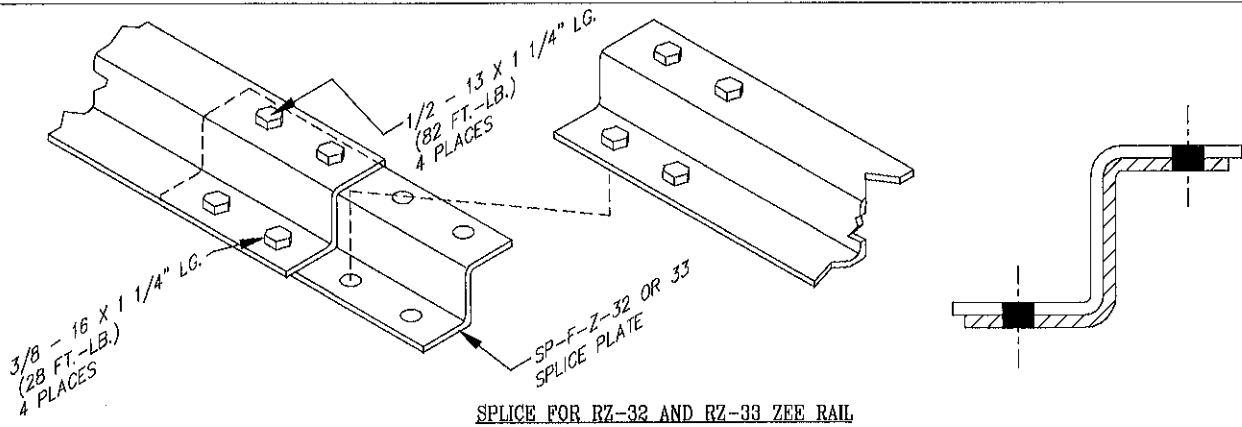
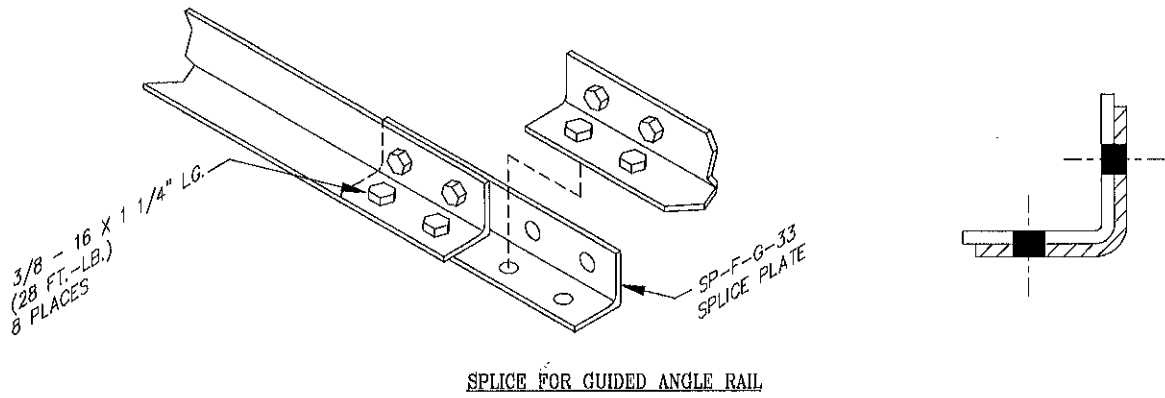
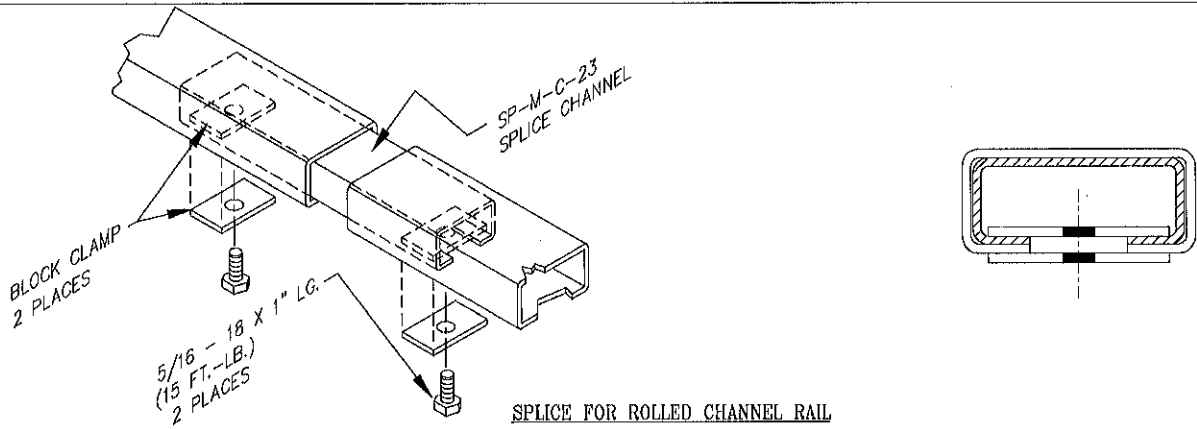

## IX. OPTIONAL COMPONENTS

Most optional components are not covered under the standard installation procedure. The following may be included in your system. Options should be identified within the "Supplemental Drawings", "Bill of Material" or "Special Instructions"(as stated in step 5), early in the installation process to avoid unnecessary delays and having to rework the system.

### A. REINFORCED UPRIGHT FRAMES

UPRIGHT FRAMES LOCATED AT THE AISLES OR THE ENDS OF THE ROWS MAY CONTAIN ADDITIONAL PROTECTION. THIS IS USUALLY IN THE FORM OF A SINGLE CHANNEL REINFORCEMENT (SENTRY I) OR TWO CHANNELS (SENTRY II) EXTENDING UP TO THE FRAMES HORIZONTAL CROSS PIECE.

(NOTE: FIELD DRILLING THROUGH THE REINFORCEMENT MAY BE REQUIRED IN SOME SENTRY II CONDITIONS.)

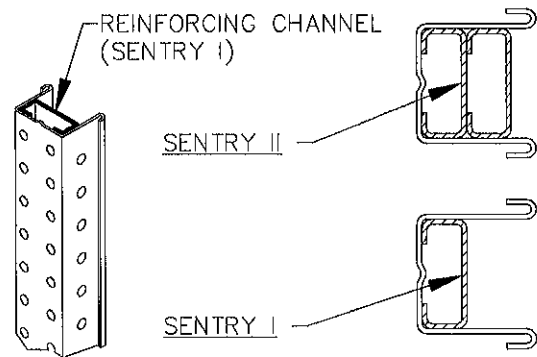

### B. "TEE" & "ELL" ALTERNATE CONNECTORS

THESE "TEE" & "ELL" PALLET RAIL SUPPORTS ARE USED WHEN THE REINFORCING CHANNEL PROHIBITS BOLTING THRU THE FRONT FACE OF THE COLUMN. THESE CONNECTORS REQUIRE BOLTING THRU THE SIDE HOLES IN THE COLUMN. BOLTS FOR THESE SUPPORTS ARE 4" OR 5" LONG DEPENDING ON THE COLUMN SIZE.

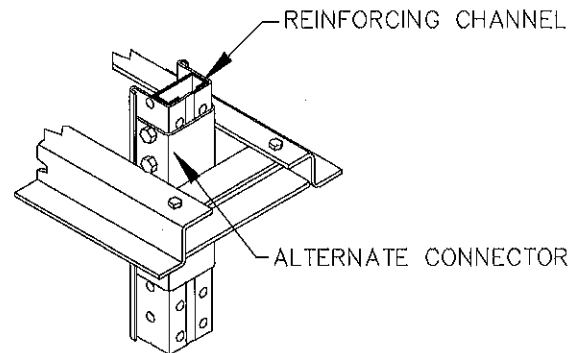

### C. SELF POSITIONING SHIMS

SHIMS MAY BE REQUIRED FOR THE PLUMBING AND LEVELING OF FRAMES IN INSTALLATIONS WHERE THE FLOOR SURFACE IS NOT LEVEL. RIDG-U-RAK METAL SHIMS ARE INSTALLED ALIGNING THE LAG HOLES AND DIMPLES WITH THE EXISTING FLOOR PADS. A COMBINATION OF SEVERAL THICKNESSES MAY BE INSTALLED IF NECESSARY.

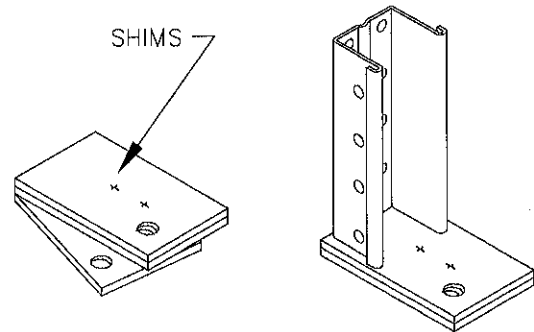

### D. PALLET STOPS

THESE PALLET STOPS ARE BOLTED TO THE REAR OF THE RACKS ON EACH PALLET RAIL. PALLET STOPS ARE INSTALLED UNDER THE PALLET RAILS USING THE EXISTING PALLET RAIL BOLTS AND NUTS.

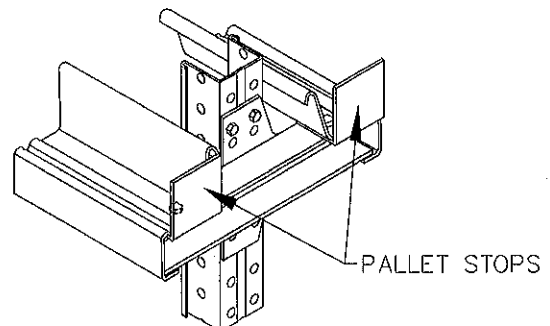

## IX. OPTIONAL COMPONENTS (continued)

Most optional components are not covered under the standard installation procedure. The following may be included in your system. Options should be identified within the "Supplemental Drawings", "Bill of Material" or "Special Instructions" (as stated in step 5), early in the installation process to avoid unnecessary delays and having to rework the system.

### E. ENTRY GUIDES ("TEE" & "ELL" SUPPORTS)

ENTRY GUIDES ARE INSTALLED ON THE FRONT COLUMN OF THE FRAMES NEAREST THE AISLE ONLY.  
ENTRY GUIDES INSTALL THE SAME AS STANDARD "TEE" & "ELL" PALLET RAIL SUPPORTS.

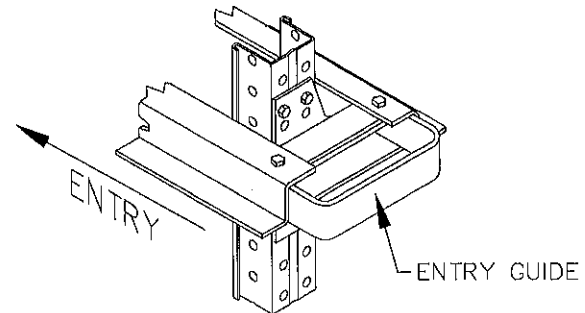

### F. COLUMN GUARDS

UPRIGHT FRAMES LOCATED AT THE AISLES MAY UTILIZE THE ADDITIONAL PROTECTION OF COLUMN GUARDS. COLUMN GUARDS COME IN VARIOUS STYLES WHICH ARE USUALLY BOLTED TO THE FRAME OR LAGGED TO THE FLOOR.

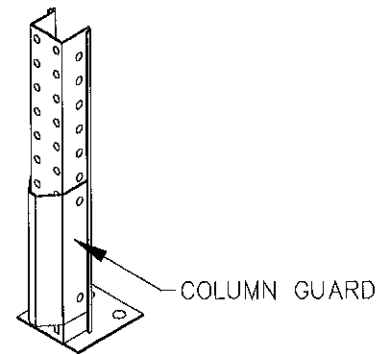

### G. FULL DEPTH BASE CHANNEL & BULL NOSE

THE FULL DEPTH BASE CHANNEL IS USED WHEN THERE IS A DEMAND FOR INCREASED STABILITY, A GREATER AREA OF WEIGHT BEARING SURFACE & AS FLOOR GUIDES. THE FRAMES ARE STOOD IN THE BASE CHANNELS ON THE CHALK LINES. THEN THE HOLES IN THE BASE CHANNEL AND FRAME ARE LINED UP FOR THE LAG BOLTS. THE BULL NOSE IS USED AS AN ENTRY GUIDE & ADDED PROTECTION TO THE FRAME. ONE LAG IS USED PER BULL NOSE.

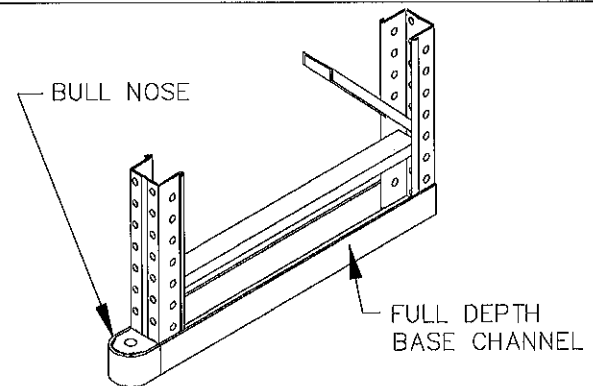

### H. SLANT-BAK UPRIGHT FRAMES

SLANT-BAK FRAMES ISOLATE THE COLUMN FROM AISLE TRAFFIC. THEY ARE INSTALLED THE SAME AS STANDARD FRAMES. THE SLANTED LEG OF THE FRAME SHOULD FACE THE AISLE SIDE OF THE RACK SYSTEM.

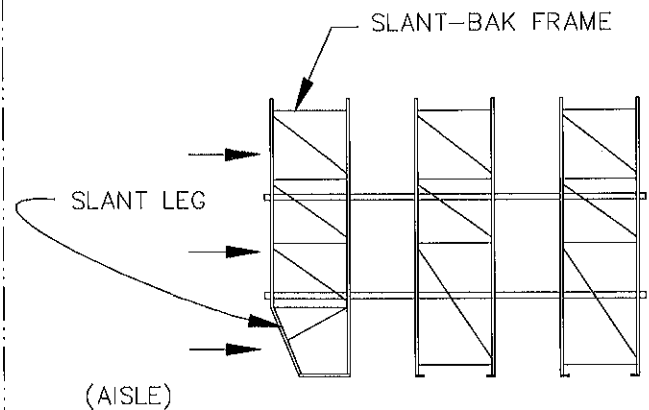

X. ISLAND DRIVE-IN RACK PROFILES: 2 pallet high (1 rail level)

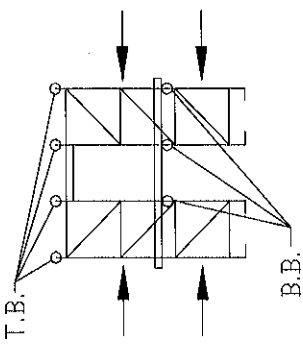
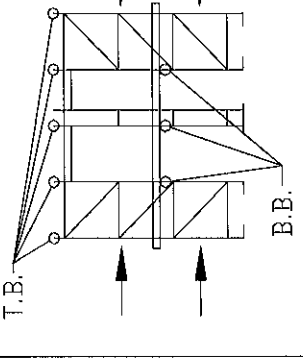
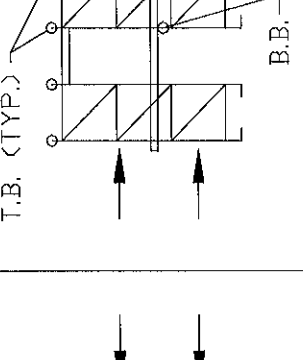
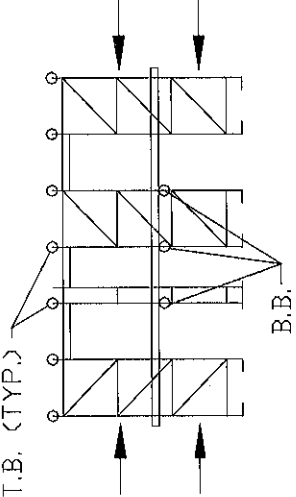
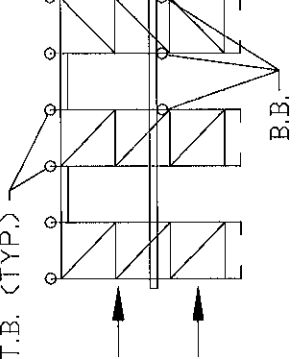
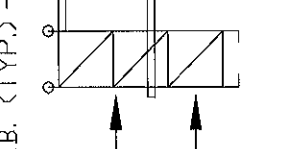
ISLAND DRIVE-IN RACK PROFILES: 2 PALLET HIGH, (1 RAIL LEVEL)													
2 DEEP	2 DP. / 1 DP.	2 DP. / 2 DP.	3 DP. / 2 DP.										
NONE													
3 DP. / 3 DP.	4 DP. / 3 DP.	4 DP. / 4 DP.											
													
<p>SPACER/ FRAME HEIGHT CHART</p> <table border="1"> <thead> <tr> <th>FRAME HGT.</th> <th>NO. OF ROW SPACERS HIGH</th> </tr> </thead> <tbody> <tr> <td>UP TO 18'</td> <td>1</td> </tr> <tr> <td>19' THRU 22'</td> <td>2</td> </tr> <tr> <td>23' THRU 29'</td> <td>3</td> </tr> <tr> <td>OVER 29'</td> <td>VARIES</td> </tr> </tbody> </table>				FRAME HGT.	NO. OF ROW SPACERS HIGH	UP TO 18'	1	19' THRU 22'	2	23' THRU 29'	3	OVER 29'	VARIES
FRAME HGT.	NO. OF ROW SPACERS HIGH												
UP TO 18'	1												
19' THRU 22'	2												
23' THRU 29'	3												
OVER 29'	VARIES												
<p>NOTES:</p> <ol style="list-style-type: none"> <li>1. "B.B." INDICATES BASIC BEAMS</li> <li>2. "T.B." INDICATES TOP BRACES</li> <li>3. ISLAND DRIVE-IN RACKS OVER (5) PALLETS DP. MUST BE TIED TO BLD'G. COLUMNS OR OTHER BLD'G. MEMBERS FOR LATERAL STABILITY.</li> </ol>													

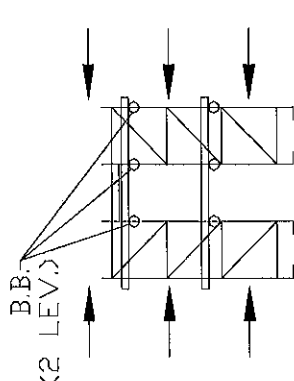
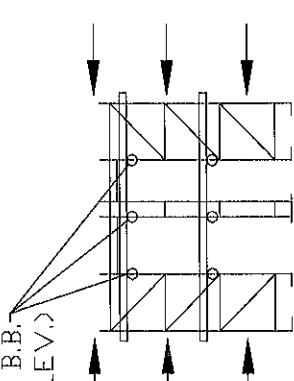
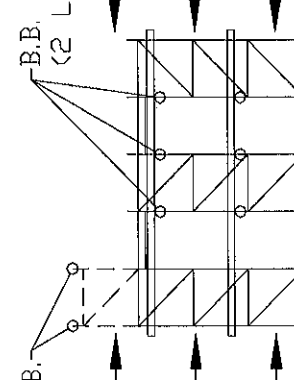
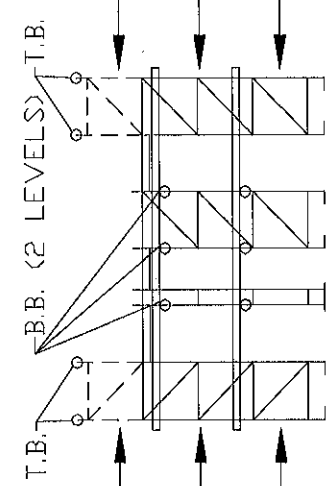
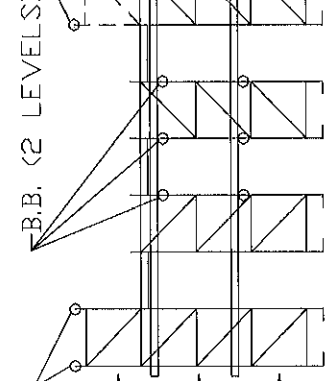
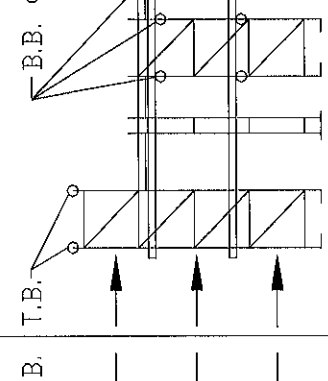
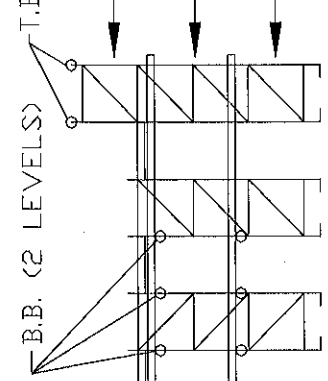

X. ISLAND DRIVE-IN RACK PROFILES: 3 pallet high (2 rail levels)

ISLAND DRIVE-IN RACK PROFILES: 3 PALLET HIGH, (2 RAIL LEVELS)			
2 DEEP	2 DP. / 1 DP.	2 DP. / 2DP.	3 DP. / 2 DP.
NONE			
3 DP. / 3 DP.	4 DP. / 3 DP.	4 DP. / 4 DP.	
			
<p>NOTE: ALL RACKS HAVING MORE RAIL LEVELS THAN THE ABOVE WILL BE THE SAME AS THE (2) RAIL LEVEL RACKS EXCEPT THAT THEY WILL REQUIRE THE ADDITIONAL RAIL LEVELS.</p>			
SPACER/ FRAME HEIGHT CHART		NOTES:	
FRAME HGT.	ND. OF ROW SPACERS HIGH	<ol style="list-style-type: none"> <li>HIGH FRAMES SHOWN IN PHANTOM WITH TOP BRACES ARE ONLY AT THE 1ST AND 2ND FRAME LOCATIONS FROM BOTH ENDS OF THE RACK.</li> <li>"B.B." INDICATES BASIC BEAMS</li> <li>"T.B." INDICATES TOP BRACES</li> <li>ISLAND DRIVE IN RACKS OVER (5) PALLETS DP. MUST BE TIED TO BLD'G. COLUMNS OR OTHER BLD'G. MEMBERS FOR LATERAL STABILITY.</li> </ol>	
UP TO 18'	1		
19' THRU 22'	2		
23' THRU 29'	3		
OVER 29'	VARIABLES		



## XII. SUPPLEMENTAL DRAWINGS

Within this installation guide package there are supplemental drawings and documents to support the installation crew. These drawings / documents are specifically produced for this installation and will provide pertinent information. They will show rack profiles, locations and dimensions along with other important parameters. Reading this guide and studying the drawing(s) and document(s) associated with this installation package is an important starting point in your installation. All instructions, including building construction drawings, Ridg-U-Rak drawings, the bill of material and this installation guide should be reviewed thoroughly by the customer and the installer before installation and use. By doing so you will provide yourself with the information needed to use as a basic guide when erecting an ISLAND DRIVE-IN rack system. Any question regarding the layout, installation procedure, components, or documents after reading this installation guide and supplemental drawing package should be brought to the attention of Ridg-U-Rak, Inc.

(NOTE: It should be certain before using these drawings/documents that the customer has approved them for construction).

The number of drawings / documents attached to this installation guide is: \_\_\_\_\_

Please be sure all information is accounted for.